

Electric Chain Hoists



Ingersoll Rand Quantum QCH Series electric chain hoists bring outstanding control, reliability, long life, and safety to your load handling operations. Available in both single and dual-speed options — as well as lifting capacities ranging from 0.125 to 5 ton — Quantum QCH Series hoists meet or exceed H3 duty-cycle standards for world-class performance. They are also the only hoist family UL and C-UL listed, with third-party evaluation limiting liability.

Quantum QCH Series hoists feature geared limit switches and pendants with e-stops as standard. They offer low-headroom profiles and are easily customized to your application.

Quantum Series

0.125 to 5 metric ton lifting capacities

Features

Smooth, quiet operation — Helical / spur gear combination provides smooth movement and quiet, reliable operation. A floating chain guide precisely feeds chain onto a machine-matched, five-pocket chain wheel. This system ensures smooth, jam-resistant operation.

Durability — Quantum load chains are precision-formed from alloy steel, case hardened and zinc-plated. The plating is an Ingersoll Rand proprietary process that resists corrosion better than any standard plating offered for load chain.

Reliability — With high starting torque, Quantum motors use a totally enclosed non-ventilated (TENV) squirrel cage design. Class F insulation provides a total thermal rating of 145°C at a 1.0 service factor, instead of the more common Class B insulation of 120° C.

Safety — State-of-the-art AC motor brakes with all-steel discs. Multiple stacking significantly increases braking surface area, reducing wear and extending life. Quantum brake discs are guaranteed for the life of the hoist. The overload clutch is factory-set to limit Quantum from lifting loads in excess of 150% of rated hoisting capacity.

Ergonomics — Safety-first pendent control handles are comfortable and fit securely in the operator's hand. Each low-voltage (42-volt) control handle integrates a large, red emergency stop button. Operating buttons are clearly marked with high contrast arrows, feature soft-push action, and are horizontally aligned for easier operation.



Electric Chain Hoists

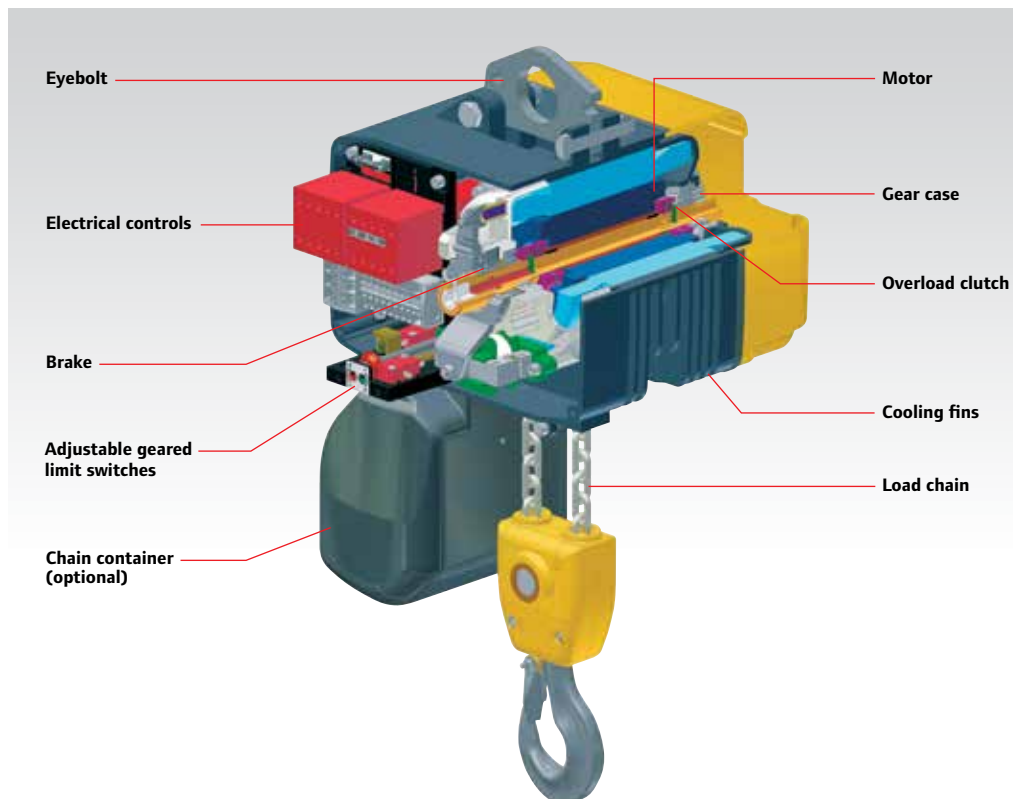

Quantum Series

0.125 to 5 metric ton lifting capacities

Quantum Series Specifications

Model	Capacity		# Falls	Motor hp	Hook Mount Headroom		Trolley Mount Headroom		Lifting Speed Rated Load or No Load		Lowering Speed Rated Load or No Load		Chain Weight (per foot of lift)		Net Weight w/10 ft of lift	
	lb	metric tons			in	mm	in	mm	ft/min	m/min	ft/min	m/min	lb	kg	lb	kg
THREE-PHASE (SINGLE SPEED)																
QCH50-1NS12	275	0.125	1	1	17.1	435	17.4	441.3	32	9.8	32	9.8	0.4	0.2	45	20.4
QCH50-1NS25	550	0.25	1	1	17.1	435	17.4	441.3	32	9.8	32	9.8	0.4	0.2	45	20.4
QCH50-1NS50	1,100	0.50	1	1	17.1	435	17.4	441.3	32	9.8	32	9.8	0.4	0.2	45	20.4
QCH50-2NS100	2,200	1	2	1	18.8	476.3	18.9	481	16	4.9	16	4.9	0.7	0.3	50	22.7
QCH100-1NS100	2,200	1	1	2.1	21.8	553.2	21.5	545.3	32	9.8	32	9.8	0.7	0.3	99	44.9
QCH100-2NS200	4,400	2	2	2.1	24.7	627.1	24.4	619.9	16	4.9	16	4.9	1.4	0.6	110	49.9
QCH300-1NS200	4,400	2	1	4.2	25.4	646.1	26.4	671.5	32	8	32	9.8	1.5	0.7	143	64.9
QCH200-2NS300	6,600	3	2	3.2	28.7	727.9	29.8	756.4	16	4.9	16	4.9	3	1.4	161	73
QCH300-2NS400	8,800	4	2	4.2	28.7	727.9	29.7	753.3	16	4.9	16	4.9	3	1.4	168	76.2
QCH500-2NS500	11,000	5	2	4.2	28.7	727.9	29.7	754.9	12.5	3.8	12.5	3.8	3	1.4	168	76.2
THREE-PHASE (DUAL SPEED)																
QCH50-1ND12	275	0.125	1	1	17.1	435	17.4	441.3	32 / 8	9.8 / 2.4	32 / 8	9.8 / 2.4	0.4	0.2	50	22.7
QCH50-1ND25	550	0.25	1	1	17.1	435	17.4	441.3	32 / 8	9.8 / 2.4	32 / 8	9.8 / 2.4	0.4	0.2	50	22.7
QCH50-1HD25	550	0.25	1	1	17.1	435	17.4	441.3	50 / 12	15.2 / 3.7	50 / 12	15.2 / 3.7	0.4	0.2	50	22.7
QCH50-1ND50	1,100	0.50	1	1	17.1	435	17.4	441.3	32 / 8	9.8 / 2.4	32 / 8	9.8 / 2.4	0.4	0.2	50	22.7
QCH50-2ND100	2,200	1	2	1	18.8	476.3	18.9	481	16 / 4	4.9 / 1.2	16 / 4	4.9 / 1.2	0.7	0.3	55	24.9
QCH100-1ND100	2,200	1	1	2.1	21.8	553.2	21.5	545.3	32 / 8	9.8 / 2.4	32 / 8	9.8 / 2.4	0.7	0.3	101	45.8
QCH100-2ND200	4,400	2	2	2.1	24.7	627.1	24.4	619.9	16 / 4	4.9 / 1.2	16 / 4	4.9 / 1.2	1.4	0.6	112	50.8
QCH300-1ND200	4,400	2	1	4.2	25.4	646.1	26.4	671.5	32 / 8	9.8 / 2.4	32 / 8	9.8 / 2.4	1.5	0.7	147	66.7
QCH200-2ND300	6,600	3	2	3.2	28.7	727.9	29.8	756.4	16 / 4	4.9 / 1.2	16 / 4	4.9 / 1.2	3	1.4	165	74.8
QCH300-2ND400	8,800	4	2	4.2	28.7	727.9	29.7	753.3	16 / 4	4.9 / 1.2	16 / 4	4.9 / 1.2	3	1.4	172	78
QCH500-2ND500	11,000	5	2	4.2	28.7	727.9	29.7	754.9	12.5 / 3	3.8 / 0.9	12.5 / 3	3.8 / 0.9	3	1.4	172	78



Eyebolt and hook suspension



Motorized trolley suspension



PT Series plain trolley with hook suspension

Quantum Series

0.125 to 5 metric ton lifting capacities

Handy Handle control — QCH50 models only

This ergonomically designed control enables precise operation at the hook and acts as a robotic power extension of the operator's arm. The load can be positioned and controlled with one hand, freeing the other to position the load.

The Handy Handle can be ordered separately as part of a kit, to convert any 0.125-, 0.25-, and 0.50-ton single-line Quantum hoist, or as an "H" control option on a new hoist. Each Handy Handle comes standard with single- or dual-speed thumb control lever switches and red emergency stop button. A socket connection at the bottom allows the standard hook to be easily replaced by custom-end effectors or grabs.



Quantum Series Motorized Trolley Specifications – M1, M2, and M4

Model	Traverse Speed ft/min (m/min)			Amperage			Min. in (mm)	Min. in (mm)	Flange Width in (mm)				Weight lb (kg)	
	M1	M2	M4	230V	460V	575V	Beam Height	Curve Radius	A	B	C	D		
QCH50-1NS12														
QCH50-1ND12														
QCH50-1NS25														
QCH50-1ND25							4 (101.6)	48 (1219.2)	2.0 - 3.9 (50.8 - 99.1)	4.0 - 5.9 (101.6 - 149.9)	6.0 - 7.8 (152.4 - 198.1)	7.9 - 9.4 (200.7 - 238.8)	60 (27.2)	
QCH50-1NS50														
QCH50-1ND50														
QCH50-2NS100														
QCH50-2ND100														
QCH100-1NS100				1.5	0.75	0.6								
QCH100-1ND100	48 (14.6)	48/16 (14.6/4.9)	72/24 (21.9/7.3)				6 (152.4)	60 (1524.0)	3.0 - 5.5 (76.2 - 139.7)	5.6 - 7.8 (142.2 - 198.1)	7.9 - 10.2 (200.7 - 259.1)	10.3 - 12.6 (261.6 - 320.0)	70 (31.7)	
QCH100-2NS200														
QCH100-2ND200														
QCH300-1NS200														
QCH300-1ND200														
QCH200-2NS300														
QCH200-2ND300							6 (152.4)	72 (1828.8)	2.2 - 4.7 (55.9 - 119.4)	4.8 - 7.0 (121.9 - 177.8)	7.1 - 9.4 (180.3 - 238.8)	9.5 - 11.8 (241.3 - 299.7)	110 (49.9)	
QCH300-2NS400														
QCH300-2ND400														
QCH500-2NS500				3	1.5	1.2								
QCH500-2ND500														

Quantum Series

0.125 to 5 metric ton lifting capacities

Quantum Series Dimensions

QCH Base Model	Capacity			Headroom											
	lb	Metric Tons	Falls	Eyebolt (AE)		Hook (AH)		Push Trolley (AP)		Motor Trolley (AM)		Hook (B)		Hook (C)	
				in	mm	in	mm	in	mm	in	mm	in	mm	in	mm
THREE PHASE (SINGLE SPEED)															
QCH50-1NS12	275	0.125	1	14.8	375.9	17.1	434.3	17.4	442	16.8	426.7	0.9	22.9	1	25.4
QCH50-1NS25	550	0.25	1	14.8	375.9	17.1	434.3	17.4	442	16.8	426.7	0.9	22.9	1	25.4
QCH50-1NS50	1,100	0.50	1	14.8	375.9	17.1	434.3	17.4	442	16.8	426.7	0.9	22.9	1	25.4
QCH50-2NS100	2,200	1	2	16.4	416.6	18.8	477.5	18.9	480.1	18.3	464.8	0.9	22.9	1	25.4
QCH100-1NS100	2,200	1	1	19	482.6	21.8	553.7	21.5	546.1	21.3	541	1	25.4	1.3	33
QCH100-2NS200	4,400	2	2	21.9	556.3	24.7	627.4	24.4	619.8	24.3	617.2	1	25.4	1.3	33
QCH300-1NS200	4,400	2	1	23.9	607.1	25.4	645.2	26.4	670.6	26.2	665.5	1.5	38.1	1.6	40.6
QCH200-2NS300	6,600	3	2	27.2	690.9	28.7	729	29.8	756.9	29.3	744.2	1.5	38.1	1.6	40.6
QCH300-2NS400	8,800	4	2	27.2	690.9	28.7	729	29.7	754.4	29.3	744.2	1.5	38.1	1.6	40.6
QCH500-2NS500	11,000	5	2	27.2	690.9	28.7	729	29.7	754.4	29.3	744.2	1.5	38.1	1.6	40.6
THREE PHASE (DUAL SPEED)															
QCH50-1ND12	275	0.125	1	14.8	375.9	17.1	434.3	17.4	442	16.8	426.7	0.9	22.9	1	25.4
QCH50-1ND25	550	0.25	1	14.8	375.9	17.1	434.3	17.4	442	16.8	426.7	0.9	22.9	1	25.4
QCH50-1HD25	550	0.25	1	14.8	375.9	17.1	434.3	17.4	442	16.8	426.7	0.9	22.9	1	25.4
QCH50-1ND50	1,100	0.50	1	14.8	375.9	17.1	434.3	17.4	442	16.8	426.7	0.9	22.9	1	25.4
QCH50-2ND100	2,200	1	2	16.4	416.6	18.8	477.5	18.9	480.1	18.3	464.8	0.9	22.9	1	25.4
QCH100-1ND100	2,200	1	1	19	482.6	21.8	553.7	21.5	546.1	21.3	541	1	25.4	1.3	33
QCH100-2ND200	4,400	2	2	21.9	556.3	24.7	627.4	24.4	619.8	24.3	617.2	1	25.4	1.3	33
QCH300-1ND200	4,400	2	1	23.9	607.1	25.4	645.2	26.4	670.6	26.2	665.5	1.5	38.1	1.6	40.6
QCH200-2ND300	6,600	3	2	27.2	690.9	28.7	729	29.8	756.9	29.3	744.2	1.5	38.1	1.6	40.6
QCH300-2ND400	8,800	4	2	27.2	690.9	28.7	729	29.7	754.4	29.3	744.2	1.5	38.1	1.6	40.6
QCH500-2ND500	11,000	5	2	27.2	690.9	28.7	729	29.7	754.4	29.3	744.2	1.5	38.1	1.6	40.6

Quantum Series Weight

QCH Base Model	Eyebolt or Hook		Push Trolley		Motor Trolley	
	lb	kg	lb	kg	lb	kg
THREE PHASE (SINGLE SPEED)						
QCH50-1NS12	45	20.4	65	29.5	105	47.6
QCH50-1NS25	45	20.4	65	29.5	105	47.6
QCH50-1NS50	45	20.4	65	29.5	105	47.6
QCH50-2NS100	50	22.7	80	36.3	110	49.9
QCH100-1NS100	99	44.9	129	58.5	173	78.5
QCH100-2NS200	110	49.9	165	74.8	184	83.4
QCH300-1NS200	143	64.9	198	89.8	257	116.6
QCH200-2NS300	161	73	236	107	281	127.4
QCH300-2NS400	168	76.2	274	124.3	282	127.9
QCH500-2NS500	168	76.2	274	124.3	282	127.9
THREE PHASE (DUAL SPEED)						
QCH50-1ND12	50	22.7	70	31.7	110	49.9
QCH50-1ND25	50	22.7	70	31.7	110	49.9
QCH50-1HD25	50	22.7	70	31.7	110	49.9
QCH50-1ND50	50	22.7	70	31.7	110	49.9
QCH50-2ND100	55	24.9	85	38.5	115	52.2
QCH100-1ND100	101	45.8	131	59.4	175	79.4
QCH100-2ND200	112	50.8	167	75.7	186	84.4
QCH300-1ND200	147	66.7	202	91.6	261	118.4
QCH200-2ND300	165	74.8	240	108.8	285	129.3
QCH300-2ND400	172	78.0	278	126.1	286	129.7
QCH500-2ND500	172	78.0	278	126.1	286	129.7

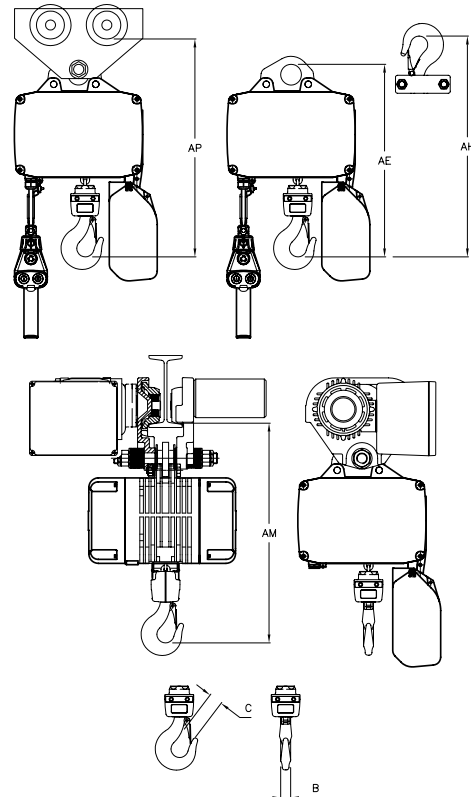

Electric Chain Hoists

Quantum Series

0.125 to 5 metric ton lifting capacities

► HOW TO ORDER

Example: QCH100-2NS200M1-21-17B4C

QCH100-2NS200

M1

21

17

B

4

C

Base model

3 phase single speed

QCH50-1NS12
QCH50-1NS25
QCH50-1NS50
QCH50-2NS100
QCH100-1NS100
QCH100-2NS200
QCH300-1NS200
QCH200-2NS300
QCH300-2NS400
QCH500-2NS500

3 phase dual-speed

QCH50-1ND12
QCH50-1ND25
QCH50-1HD25
QCH50-1ND50
QCH50-2ND100
QCH100-1ND100
QCH100-2ND200
QCH300-1ND200
QCH200-2ND300
QCH300-2ND400
QCH500-2ND500

Suspension type

E = Eye bolt
H = Hook
P = Plain trolley ("PT" Series)
M1 = Motorized trolley (normal speed 48 fpm)
M2 = Motorized trolley (normal/dual speed 48/16 fpm)
M4 = Motorized trolley (high/dual speed 96/24 fpm)

Lift (feet)

10 = Standard
15 = Standard
20 = Standard
XX = Specify length

Pendent drop (feet)

6 = Standard
11 = Standard
16 = Standard
XX = Specify length

Flange width (See catalog for specifications)

- = Eye bolt or hook mount
A = See flange width chart
B = See flange width chart
C = See flange width chart
D = See flange width chart

Voltage

3 = 230/3/60
4 = 460/4/60
5 = 575/3/60
6 = 380/3/50*
(* = these units have extended lead times and are not UL or C-UL (Canadian UL) listed)

Options

B = Trolley brake
C = Chain container
E = External strain relief
F = XX, specify power cord length (standard is 15 ft on E, H, and P, and 3 ft on M1-M4 suspensions)
H = Handy Handle (QCH50 single fall only)
K = 110 volt control (3 phase models only)
P = Pendent with vertical aligned buttons
P2 = Pendent with 2 extra vertical aligned buttons
P4 = Pendent with 4 extra vertical aligned buttons
Y = Bullard top hook
Z = Bullard bottom hook

人體工學搬運系統



產品諮詢與銷售 (台灣地區)

元裝企業有限公司
桃園市平鎮區民族路3段159巷99號
TEL:03-4923555
www.toposc.com